

BRAILLO ● 400 SR

Advanced interpoint Braille printer for large volume production

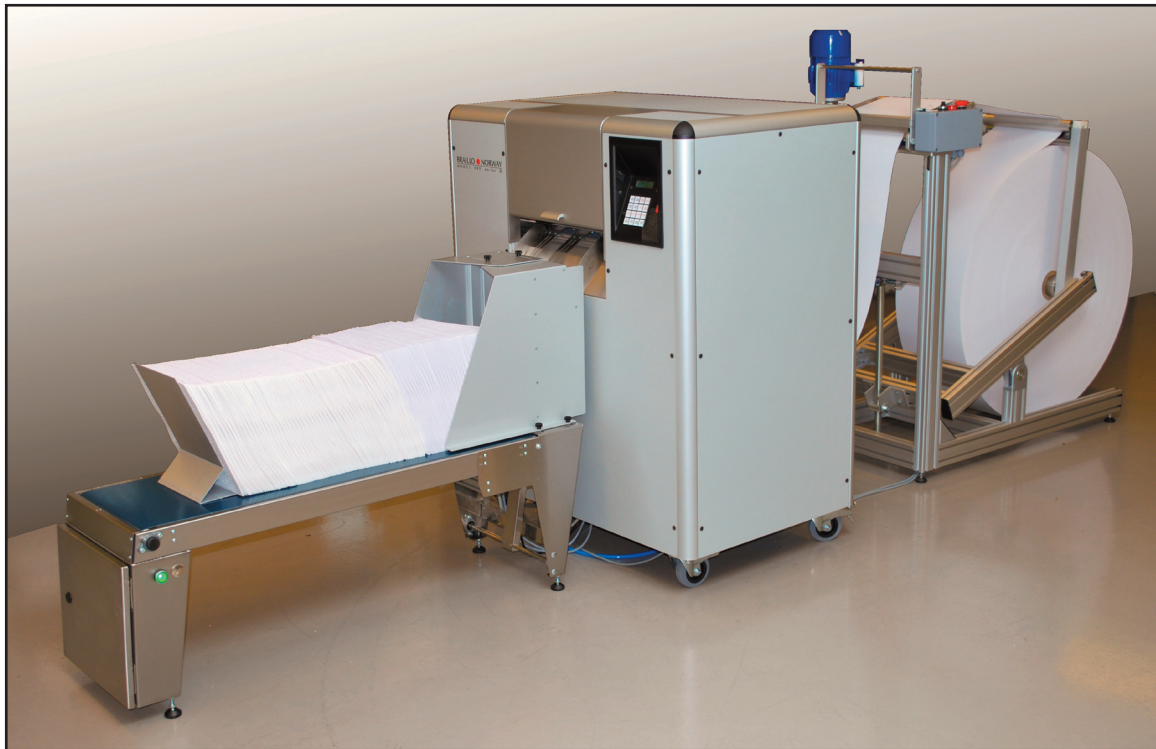

- Rugged construction for large volume production of Braille.
- Built-in Paper Cutter
- Stacking unit designed for handling Braille documents.
- Modular design, easy to service.
- Uses standard paper rolls up to 1 meter in diameter.
- 2 years warranty on parts.
- Prints simultaneously on both sides of paper.
- High speed, 1200 pages per hour continuous printing
- High Braille quality. Each document is an original.
- The printing system is based on Braillo 400 S with more than 25 years of experience.

Technical Specifications Braillo 400 SR

Format:

Char. per line: 10 - 42 characters
Sheet length: 4 - 14 inches
Sheet width: 140 - 330 mm
Page layout: Normal / Z-fold, Page 1 up / down
Printing Mode: Single / Interpoint
Braille cell: Standard medium 6 or 8 dot
Line spacing: From 0.3175 to 10.16 mm, Standard is 5.08 mm
Paper Weight: 120 - 180 g/m², Recommended 150 g/m²

Printing Speed: 400 characters per second,
approx. 1200 printed pages per hour.

Electrical:

Voltage: Single phase 230V (+/- 10 %), 50/60Hz
Current: Approx. 4 A max
Fuse Printer: 10 A
Power: Approx. 1000 W max

Communication with the computer:

Parallel on Centronics (25 pin D-sub female), or
Serial on RS 232 C (25 pin D-sub male).
Both are electrical isolated with opto-couplers
to prevent noise and ground loops.

Parameters for the serial port:

Baud rate: 150 - 19200
Parity: No / Odd / Even
Data bit: 7 / 8
Stop bit: 1 / 2

Environment:

Temperatures: 15 - 30°C (60 - 86°F)
Rel. Humidity: 40 - 60%

Measurements:

Height: 1430 mm
Width: 1027 mm
Length: 3550 mm
Weight: 300 kilos

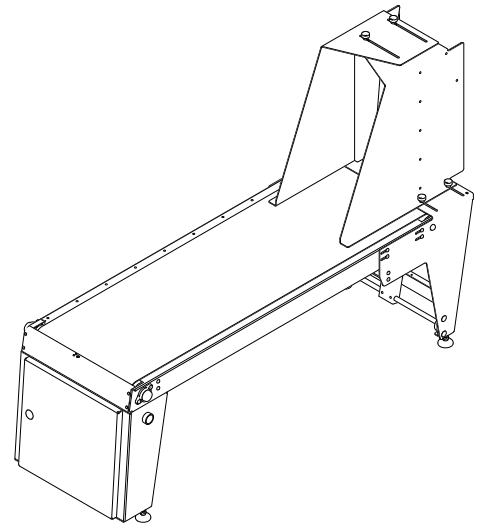

Paper Stacker

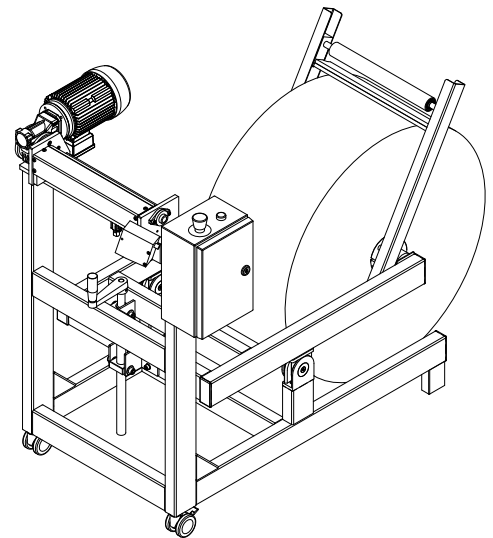

Paper Roll Feeder

Top view

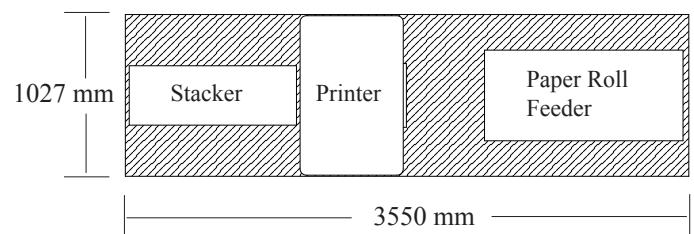

The manufacturer reserves the right to change the specifications without further notice.

Produced and marketed by:

Distributed by:

BRAILLO NORWAY AS

P. O. Box 447

3101 Tønsberg, Norway

Phone: +47 33 00 28 70

Fax: +47 33 00 28 71

E-mail: braillo@braillo.no

Internet: www.braillo.com