

BRAILLO ● 400 S

Advanced interpoint Braille printer for large volume production



- Rugged construction for large volume production of Braille.
- Low noise.
- Prints both 6 and 8 dot Braille.
- Modular design, easy to service.
- Uses standard fanfolded paper in a variety of formats.
- 2 years warranty on parts.
- Prints simultaneously on both sides of paper.
- High speed, 1200 pages per hour continuous printing.
- High Braille quality. Each document is an original.
- Thoroughly tested with years of experience by many internationally known users.

Technical Specifications Braillo 400 S

Format:

Char. per line: 10 - 42 characters
Sheet length: 4 - 14 inches
Sheet width: 140 - 330 mm
Page layout: Normal / Z-fold
Page 1: Up / Down
Printing Mode: Single / Interpoint
Page Length: No form feed / Normal / Normal -1 to -9 lines
Braille cell: Standard medium 6 or 8 dot
Line spacing: From 0.3175 to 10.16 mm. Standard is 5.08 mm
Paper Weight: 120 - 180 g/m², Recommended 150 g/m²

Printing Speed: 400 characters per second, approx. 1200 printed pages per hour

Electrical:

Voltage: Single phase 230V (+/- 10 %), 50/60Hz
Current: Approx. 4 A max
Fuse Printer: 10 A
Power: Approx. 1000 W max

Communication with the computer:

Parallel on Centronics (25 pin D-sub female), or
Serial on RS 232 C (25 pin D-sub male).
Both are electrical isolated with opto-couplers
to prevent noise and ground loops.

Parameters for the serial port:

Baud rate: 150 - 19200
Parity: No / Odd / Even
Data bit: 7 / 8
Stop bit: 1 / 2

Environment:

Temperatures: 15 - 30°C (60 - 86°F)
Rel. Humidity: 40 - 60%

Measurements:

Height: 1250 mm
Width: 1027 mm
Length: 1325 mm
Weight: 195 kilos

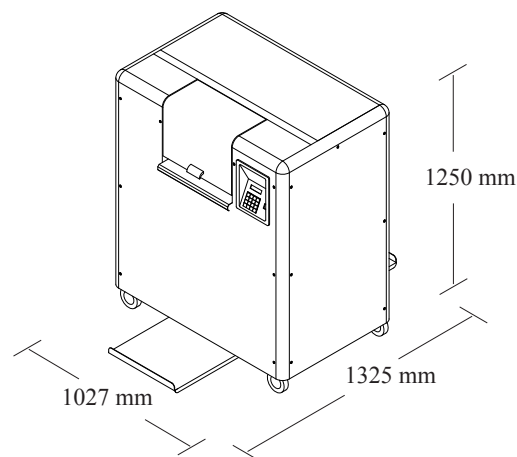

The manufacturer reserves the right to change the specifications without further notice.

Produced and marketed by:

Distributed by:

BRAILLO NORWAY AS

P. O. Box 447

3101 Tønsberg, Norway

Phone: +47 33 00 28 70

Fax: +47 33 00 28 71

E-mail: braillo@braillo.no

Internet: www.braillo.com
